



SBC86841 Series
Intel[®] Core[™] 2 Duo All-In-One
Mini ITX Board with DVI/LVDS
User's Manual

Disclaimers

This manual has been carefully checked and believed to contain accurate information. AXIOMTEK Co., Ltd. assumes no responsibility for any infringements of patents or any third party's rights, and any liability arising from such use.

AXIOMTEK does not warrant or assume any legal liability or responsibility for the accuracy, completeness or usefulness of any information in this document. AXIOMTEK does not make any commitment to update the information in this manual.

AXIOMTEK reserves the right to change or revise this document and/or product at any time without notice.

No part of this document may be reproduced, stored in a retrieval system, or transmitted, in any form or by any means, electronic, mechanical, photocopying, recording, or otherwise, without the prior written permission of AXIOMTEK Co., Ltd.

Caution

If you replace wrong batteries, it causes the danger of explosion. It is recommended by the manufacturer that you follow the manufacturer's instructions to only replace the same or equivalent type of battery, and dispose of used ones.

**©Copyright 2008 AXIOMTEK Co., Ltd.
All Rights Reserved
March 2008, Version A2
Printed in Taiwan**

ESD Precautions

Computer boards have integrated circuits sensitive to static electricity. To prevent chipsets from electrostatic discharge damage, please take care of the following jobs with precautions:

- Do not remove boards or integrated circuits from their anti-static packaging until you are ready to install them.
- Before holding the board or integrated circuit, touch an unpainted portion of the system unit chassis for a few seconds. It discharges static electricity from your body.
- Wear a wrist-grounding strap, available from most electronic component stores, when handling boards and components.

Trademarks Acknowledgments

AXIOMTEK is a trademark of AXIOMTEK Co., Ltd.

Windows[®] is a trademark of Microsoft Corporation.

Phoenix & AWARD are trademarks of Phoenix Technology Ltd.

IBM, PC/AT, PS/2, VGA are trademarks of International Business Machines Corporation.

Intel[®] and Pentium[®] are trademarks of Intel Corporation.

Winbond is a trademark of Winbond Electronics Corp.

Other brand names and trademarks are the properties and registered brands of their respective owners.

Table of Contents

Disclaimers	ii
ESD Precautions	iii
Chapter 1 Introduction	1
1.1 Specifications	2
1.2 Utilities Supported	4
Chapter 2 Jumpers and Connectors	5
2.1 Board Dimensions and Fixing Holes	5
2.2 Board Layout	7
2.3 Jumper Settings	9
2.3.1 COM1 Mode Select Jumper: JP1, JP2, JP4	10
2.3.2 COM1~COM4 Mode Select for Type Jumpers.....	11
2.3.3 LVDS Voltage Selection Jumper: JP10.....	15
2.3.4 CMOS Clear Jumper: JP9.....	15
2.3.5 Audio Output Selection Jumper: JP12	16
2.3.6 USB Power Select Jumper: JP13, JP14	16
2.4 Connectors	17
2.4.1 Print Port or Floppy Connector: CN8.....	18
2.4.2 COM2~COM4 Port Connectors: CN17, CN14, CN13.....	20
2.4.3 Digital I/O Port (DIO) Connector: CN2	20
2.4.4 DVI-I & COM1 Connector: CN3.....	21
2.4.5 LVDS Backlight Connector: CN27.....	22
2.4.6 LAN*2 Connector: CN7	23
2.4.7 USB*2 + IEEE1394 Connectors: CN11, CN12	24
2.4.8 LVDS Flat Panel Connector: CN25.....	25
2.4.9 SATA Connectors: CN19, CN20, CN21, CN22.....	26
2.4.10 Audio Phone Jack Connector: CN15.....	27
2.4.11 USB Connectors: CN16, CN18	27
2.4.12 Flat Panel Bezel Connector: CN29	28
2.4.13 Internal Audio Connector: CN23	29
2.4.14 ATX Power Connector: ATX1.....	29
2.4.15 +12V ATX Power Connector: CN1	30
2.4.16 SMBUS Connector: CN4.....	30
2.4.17 Keyboard and PS/2 Mouse Connector: CN28.....	30
2.4.18 3 Pin Fan Connectors: CN6, CN26	31
2.4.19 4 Pin Fan Connector: CN5	31
2.4.20 SPDIF Connector: CN24	31
2.4.22 PCI-EXPRESS x 4 Connector: PCIE1	32
Chapter 3 Hardware Description	33
3.1 Microprocessors	33
3.2 BIOS.....	33
3.3 System Memory.....	33
3.4 I/O Port Address Map	34
3.5 Interrupt Controller	35

Chapter 4 Award BIOS Utility	37
4.1 Entering Setup.....	37
4.2 Control Keys.....	38
4.3 Getting Help	38
4.4 The Main Menu	39
4.5 Standard CMOS Setup Menu.....	40
4.6 Advanced BIOS Features.....	42
4.7 Advanced Chipset Features	48
4.8 Integrated Peripherals	50
4.9 Power Management Setup	55
4.10 PnP/PCI Configuration Setup.....	60
4.11 PC Health Status.....	62
4.12 Frequency/Voltage Control.....	63
4.13 Load Optimized Defaults	64
4.14 Set Supervisor/User Password	65
4.15 Save & Exit Setup	66
4.16 Exit Without Saving	67
Appendix A Watchdog Timer	69
Appendix B Digital I/O.....	71

MEMO

Chapter 1

Introduction



The **SBC86841**, a Mini ITX board with LGA775 socket, supports Intel® Core™ 2 Duo desktop processor, Pentium® 4 and Pentium® D processors at FSB 533/800/1066 MHz. The board integrates chipsets Intel® Q965 and ICH8/ICH8DO that deliver outstanding system performance through high-bandwidth interfaces, multiple I/O functions for interactive applications and various embedded computing solutions. There are two 240-pin unbuffered DIMM sockets for dual channel DDR2 800/667/533 MHz memory, maximum memory capacity up to 4GB. It also features Gigabit/Fast Ethernet, four serial ATA channels for total four Serial ATA hard drives at maximum transfer rate up to 300MB/sec, eight USB 2.0 high speed compliant, built-in high definition audio codec that can achieve the best stability and reliability for industrial applications. It provides one PCI Express Mini and one PCI Express X1 through Riser Card. Additionally, it provides you with unique embedded features, such as 4 serial ports (3 x RS-232 and 1 x RS-232/422/485) and Mini ITX form factor that applies an extensive array of PC peripherals.

1.1 Specifications

- **CPU: Intel® Core™ 2 Duo, Pentium® 4 and Pentium® D processors**
- **System Chipset: Intel® Q965 & ICH8**
- **CPU Socket: LGA775**
- **Front-Side Bus: 533/800/1066MHz**
- **BIOS :**
 - Phoenix-Award BIOS, Y2K compliant
 - 16Mbit SPI Flash, DMI, Plug and Play
 - SmartView for multiple LCD type selection, display mode option and application extension features
 - “Load Optimized Default” to backup customized Setting in the BIOS flash chip to prevent from CMOS battery fail
- **System Memory :**
 - Two x 240-pin unbuffered DDR2 DIMM sockets
 - Maximum to 4GB DDR2 800/667/533 MHz memory
- **Onboard Multi I/O :**
 - Controller: Winbond W83627UHG
 - Serial Ports: 3 ports for RS-232(COM2/3/4) and 1 port for RS-232/422/485(COM1)
 - Parallel Port: One bi-directional with ECP/EPP/SPP support
 - Floppy Controller: Support for two drives (1.44MB for each)(Optional)
- **USB Interface**
 - Eight USB ports with fuse protection and complies with USB Spec. Rev. 2.0
- **Display**
 - One DVI-I for DVI via CH7307 together with Analog DAC at rear I/O with COM #1 port as stacking
 - One 40-pin connector for 24-bit dual channel LVDS via CH7308 as EFP port and 1 * 7-pin inverter connector

- **Watchdog Timer :**
 - 1~255 seconds; up to 256 levels
- **Expansion Interface :**
 - One PCI Express Mini Card(Optional)
 - One PCI Express x4 slot for 3 PCIe x1 through Riser Card
- **Ethernet :**
 - First port with i82566DM Gigabit Ethernet PHY
 - Second port with RTL8111B for Gigabit/Fast Ethernet
 - One double deck RJ-45
- **Audio :**
 - HD Audio compliant (with Speaker/line-out & MIC-in) via ALC262
 - The 2-pin 2.0 pitch wafer connector for SPDIF
 - The CD-in 4-pin 2.0 pitch wafer connector
 - Internal Audio features for speaker-out & MIC-in (L, GND, R, GND, MIC-in) via wafer connector
- **Power Management :**
 - ACPI (Advanced Configuration and Power Interface)
- **Form Factor :**
 - Mini ITX form factor



NOTE: All specifications and images are subject to change without notice.

1.2 Utilities Supported

- Chipset Driver
- Ethernet Driver
- Graphic Drivers
- Audio Drivers

Chapter 2 Jumpers and Connectors

2.1 Board Dimensions and Fixing Holes

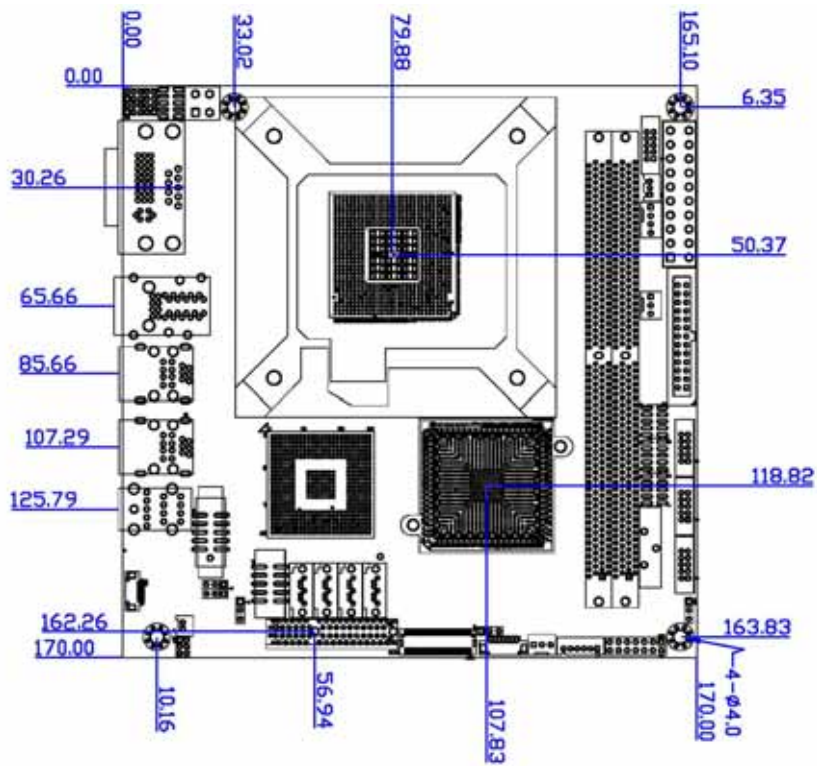

Component Side

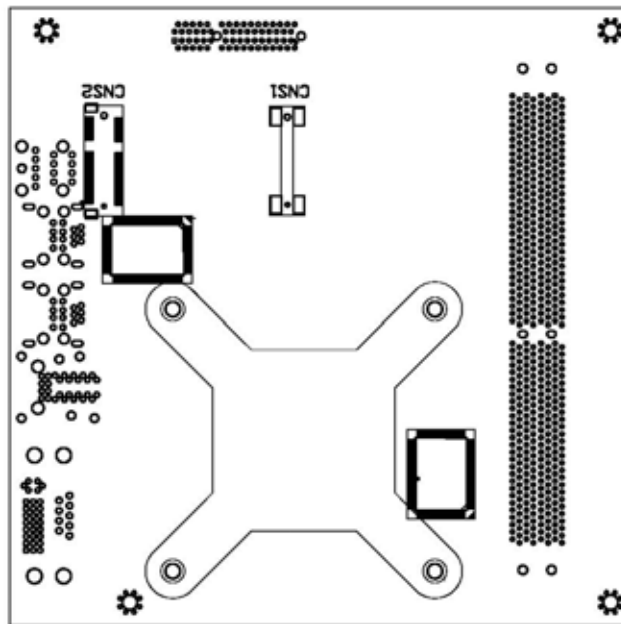

Solder Side

2.2 Board Layout

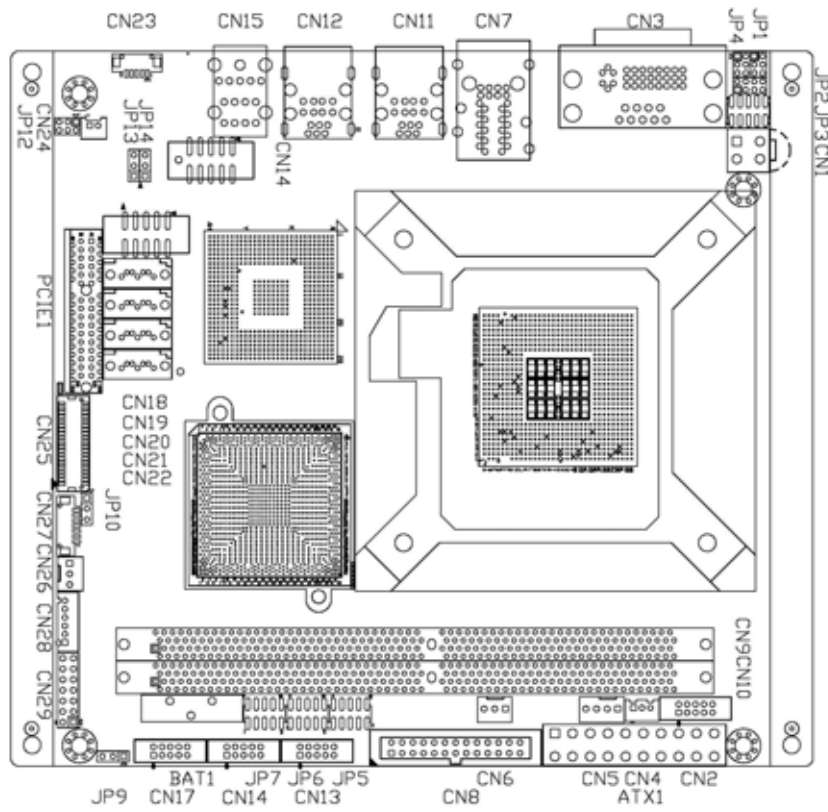

Component Side

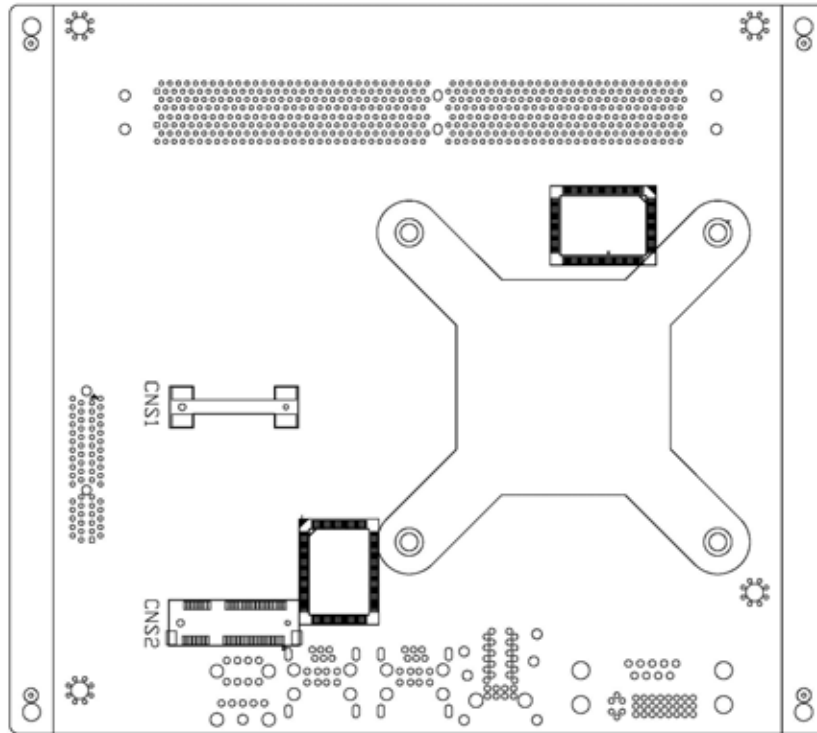

Solder Side

2.3 Jumper Settings

Proper jumper settings configure the **SBC86841** to meet your application purpose. We are herewith listing a summary table of all jumpers and default settings for onboard devices, respectively.

Here is a list of jumper settings :

Jumper	Default Setting		Jumper Setting
JP1	COM1 Mode Select Default: RS-232		Short 3-5, 4-6
JP2	COM1 Mode Select Default: RS-232		Short 1-2
JP3	COM1 Mode Select	COM1 Pin 1: DCD	Short 7-9
		COM1 Pin 9: RI	Short 8-10
JP4	COM1 Mode Select Default: RS-232		Short 3-5, 4-6
JP5	COM4 Mode Select	COM4 Pin 1: DCD	Short 7-9
		COM4 Pin 8: RI	Short 8-10
JP6	COM3 Mode Select	COM3 Pin 1: DCD	Short 7-9
		COM3 Pin 8: RI	Short 8-10
JP7	COM2 Mode Select	COM2 Pin 1: DCD	Short 7-9
		COM2 Pin 8: RI	Short 8-10
JP9	Normal Operation/Clear CMOS setting Default: Normal Operation		Short 1-2
JP10	LCD Voltage Select Default: 3.3V		Short 1-2
JP12	Audio Speak Out/Line Out Selection Default: Line Out		Short 1-3, 2-4
JP13	USB (CN18) Power Select Default: +5V		Short 1-2
JP14	USB (CN16) Power Select Default: +5V		Short 1-2

2.3.1 COM1 Mode Select Jumper: JP1, JP2, JP4













These jumpers select the COM1 port's communication mode to operate RS-232 or RS-422/485.



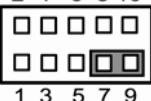
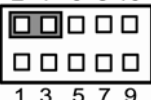





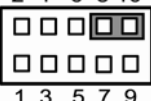

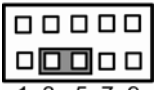

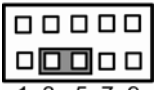
Description	Function	Jumper Setting		
COM1 Mode Select	RS-232 (Default)	<p>JP2</p>	<p>JP1</p>	<p>JP4</p>
	RS-485	<p>JP2</p>	<p>JP1</p>	<p>JP4</p>
	RS-422	<p>JP2</p>	<p>JP1</p>	<p>JP4</p>

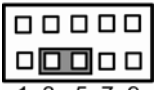

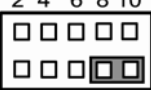
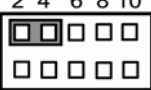





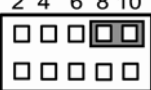



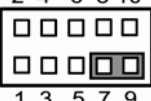

2.3.2 COM1~COM4 Mode Select for Type Jumpers: JP3, JP5, JP6, JP7

These jumpers select the COM1, COM2, COM3, COM4 ports' DCD and RI mode.

Description	Function	Jumper Setting
COM1 (CN3A)	Pin 1=12V	
	Pin 1=5V	
	*Pin 1=DCD	
	Pin 9=12V	
	Pin 9=5V	
	*Pin 9=RI	

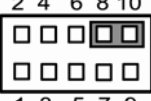

Description	Function	Jumper Setting								
COM2 (CN17)	Pin 1=12V	<p style="text-align: center;">JP7</p> <p style="text-align: center;">2 4 6 8 10</p>  <p style="text-align: center;">1 3 5 7 9</p>								
	Pin 1=5V	<table border="0" style="width: 100%; text-align: center;"> <tr> <td style="width: 50%;">JP7</td> <td style="width: 50%;">JP7</td> </tr> <tr> <td>2 4 6 8 10</td> <td>2 4 6 8 10</td> </tr> <tr> <td></td> <td></td> </tr> <tr> <td>1 3 5 7 9</td> <td>1 3 5 7 9</td> </tr> </table>	JP7	JP7	2 4 6 8 10	2 4 6 8 10			1 3 5 7 9	1 3 5 7 9
JP7	JP7									
2 4 6 8 10	2 4 6 8 10									
										
1 3 5 7 9	1 3 5 7 9									
	*Pin 1=DCD	<p style="text-align: center;">JP7</p> <p style="text-align: center;">2 4 6 8 10</p>  <p style="text-align: center;">1 3 5 7 9</p>								
	Pin 8=12V	<p style="text-align: center;">JP7</p> <p style="text-align: center;">2 4 6 8 10</p>  <p style="text-align: center;">1 3 5 7 9</p>								
	Pin 8=5V	<table border="0" style="width: 100%; text-align: center;"> <tr> <td style="width: 50%;">JP7</td> <td style="width: 50%;">JP7</td> </tr> <tr> <td>2 4 6 8 10</td> <td>2 4 6 8 10</td> </tr> <tr> <td></td> <td></td> </tr> <tr> <td>1 3 5 7 9</td> <td>1 3 5 7 9</td> </tr> </table>	JP7	JP7	2 4 6 8 10	2 4 6 8 10			1 3 5 7 9	1 3 5 7 9
JP7	JP7									
2 4 6 8 10	2 4 6 8 10									
										
1 3 5 7 9	1 3 5 7 9									
	*Pin 8=RI	<p style="text-align: center;">JP7</p> <p style="text-align: center;">2 4 6 8 10</p>  <p style="text-align: center;">1 3 5 7 9</p>								

Description	Function	Jumper Setting								
COM3 (CN14)	Pin 1=12V	<p style="text-align: center;">JP6</p> <p style="text-align: center;">2 4 6 8 10</p>  <p style="text-align: center;">1 3 5 7 9</p>								
	Pin 1=5V	<table border="0" style="width: 100%; text-align: center;"> <tr> <td style="width: 50%;">JP6</td> <td style="width: 50%;">JP6</td> </tr> <tr> <td>2 4 6 8 10</td> <td>2 4 6 8 10</td> </tr> <tr> <td></td> <td></td> </tr> <tr> <td>1 3 5 7 9</td> <td>1 3 5 7 9</td> </tr> </table>	JP6	JP6	2 4 6 8 10	2 4 6 8 10			1 3 5 7 9	1 3 5 7 9
JP6	JP6									
2 4 6 8 10	2 4 6 8 10									
										
1 3 5 7 9	1 3 5 7 9									
	*Pin 1=DCD	<p style="text-align: center;">JP6</p> <p style="text-align: center;">2 4 6 8 10</p>  <p style="text-align: center;">1 3 5 7 9</p>								
	Pin 8=12V	<p style="text-align: center;">JP6</p> <p style="text-align: center;">2 4 6 8 10</p>  <p style="text-align: center;">1 3 5 7 9</p>								
	Pin 8=5V	<table border="0" style="width: 100%; text-align: center;"> <tr> <td style="width: 50%;">JP6</td> <td style="width: 50%;">JP6</td> </tr> <tr> <td>2 4 6 8 10</td> <td>2 4 6 8 10</td> </tr> <tr> <td></td> <td></td> </tr> <tr> <td>1 3 5 7 9</td> <td>1 3 5 7 9</td> </tr> </table>	JP6	JP6	2 4 6 8 10	2 4 6 8 10			1 3 5 7 9	1 3 5 7 9
JP6	JP6									
2 4 6 8 10	2 4 6 8 10									
										
1 3 5 7 9	1 3 5 7 9									
	*Pin 8=RI	<p style="text-align: center;">JP6</p> <p style="text-align: center;">2 4 6 8 10</p>  <p style="text-align: center;">1 3 5 7 9</p>								

Description	Function	Jumper Setting								
COM4 (CN13)	Pin 1=12V	<p style="text-align: center;">JP5</p> <p style="text-align: center;">2 4 6 8 10</p>  <p style="text-align: center;">1 3 5 7 9</p>								
	Pin 1=5V	<table border="1" style="width: 100%; text-align: center;"> <tr> <td style="width: 50%;">JP5</td> <td style="width: 50%;">JP5</td> </tr> <tr> <td>2 4 6 8 10</td> <td>2 4 6 8 10</td> </tr> <tr> <td></td> <td></td> </tr> <tr> <td>1 3 5 7 9</td> <td>1 3 5 7 9</td> </tr> </table>	JP5	JP5	2 4 6 8 10	2 4 6 8 10			1 3 5 7 9	1 3 5 7 9
JP5	JP5									
2 4 6 8 10	2 4 6 8 10									
										
1 3 5 7 9	1 3 5 7 9									
	*Pin 1=DCD	<p style="text-align: center;">JP5</p> <p style="text-align: center;">2 4 6 8 10</p>  <p style="text-align: center;">1 3 5 7 9</p>								
	Pin 8=12V	<p style="text-align: center;">JP5</p> <p style="text-align: center;">2 4 6 8 10</p>  <p style="text-align: center;">1 3 5 7 9</p>								
	Pin 8=5V	<table border="1" style="width: 100%; text-align: center;"> <tr> <td style="width: 50%;">JP5</td> <td style="width: 50%;">JP5</td> </tr> <tr> <td>2 4 6 8 10</td> <td>2 4 6 8 10</td> </tr> <tr> <td></td> <td></td> </tr> <tr> <td>1 3 5 7 9</td> <td>1 3 5 7 9</td> </tr> </table>	JP5	JP5	2 4 6 8 10	2 4 6 8 10			1 3 5 7 9	1 3 5 7 9
JP5	JP5									
2 4 6 8 10	2 4 6 8 10									
										
1 3 5 7 9	1 3 5 7 9									
	*Pin 8=RI	<p style="text-align: center;">JP5</p> <p style="text-align: center;">2 4 6 8 10</p>  <p style="text-align: center;">1 3 5 7 9</p>								

2.3.3 LVDS Voltage Selection Jumper: JP10

This jumper is to select the voltage for LVDS interface.

Description	Function	Jumper Setting
LVDS Voltage Selection	3.3V (Default)	 <p>JP10 1 2 3</p>
	5V	 <p>JP10 1 2 3</p>

2.3.4 CMOS Clear Jumper: JP9

You may need to use this jumper is to clear the CMOS memory if incorrect settings in the Setup Utility.

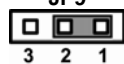
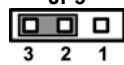
Description	Function	Jumper Setting
CMOS Clear	Normal (Default)	 <p>JP9 3 2 1</p>
	Clear CMOS	 <p>JP9 3 2 1</p>

2.3.5 Audio Output Selection Jumper: JP12

Description	Function	Jumper Setting
Audio Output Selection	Line Out (Default)	<p>JP12</p>
	Speak Out	<p>JP12</p>

2.3.6 USB Power Select Jumper: JP13, JP14

Description	Function	Jumper Setting
USB Power Select	+5VSUS	<p>JP13, JP14</p>
	5V (Default)	<p>JP13, JP14</p>

2.4 Connectors

Connectors connect the board with other parts of the system. Loose or improper connection might cause problems. Make sure all connectors are properly and firmly connected. Here is a summary table shows you all connectors on the **SBC86841** Series.

Connectors	Label
+12V ATX Power Connector	CN1
Digital I/O (DIO) Connector	CN2
COM+DVI-I Connector	CN3
SMBUS Connector	CN4
4 Pin Fan Connector	CN5
3 Pin Fan Connectors	CN6, CN26
LAN*2 Connector	CN7
Printer Port or Floppy Connector (Default : LPT)	CN8
USB*2+IEEE1394 Connectors	CN11, CN12
COM4 Connector	CN13
COM3 Connector	CN14
Audio Phone Jack Connector	CN15
USB Connectors	CN16, CN18
COM2 Connector	CN17
SATA Connectors	CN19, CN20, CN21, CN22
Internal Audio Connector	CN23
SPDIF Connector	CN24
LVDS Connector	CN25
LVDS Backlight Connector	CN27
KB/MS Connector	CN28
Flat Panel Bezel Connector	CN29
ATX Power Connector	ATX1
PCI EXPRESS X 4 Slot	PCIE1

2.4.1 Print Port or Floppy Connector: CN8

Print Port Connector [Default]

This board has a multi-mode parallel port to support:

1. Standard mode:

IBM PC/XT, PC/AT and PS/2™ compatible with bi-directional parallel port

2. Enhanced mode:

Enhance parallel port (EPP) compatible with EPP 1.7 and EPP 1.9 (IEEE 1284 compliant)

3. High speed mode:

Microsoft and Hewlett Packard extended capabilities port (ECP) IEEE 1284 compliant

Pin	Description	Pin	Description
1	Auto Form Feed#	2	Strobe#
3	Error#	4	Data 0
5	Initialize#	6	Data 1
7	Printer Select In#	8	Data 2
9	GND	10	Data 3
11	GND	12	Data 4
13	GND	14	Data 5
15	GND	16	Data 6
17	GND	18	Data 7
19	GND	20	Acknowledge#
21	GND	22	Busy
23	GND	24	Paper Empty#
25	NC	26	Printer Select

CN8

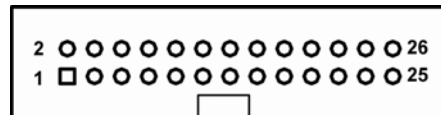

Floppy Connector [Optional]

You can plug one end of FDD cable in the FDD connector, and the other end of cable to the FDD drive. The supported type of FDD drives are 360KB, 720KB, 1.2MB, 1.44MB and 2.88MB.

Pin	Description	Pin	Description
1	NC	2	DRIVE0
3	NC	4	INDEX
5	NC	6	MOTOR ON
7	NC	8	DSKCHG
9	GND	10	DIR
11	GND	12	STEP
13	GND	14	WDATA
15	GND	16	WGATE
17	GND	18	TRK0
19	GND	20	WPT
21	GND	22	RDATA
23	GND	24	HDSEL
25	NC	26	DSKCHG

CN8

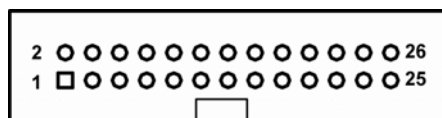

2.4.2 COM2~COM4 Port Connectors: CN17, CN14, CN13

Please refer to the RS-232 pin assignment as listed below:

Pin	Description	Pin	Description
1	Data Carrier Detect (DCD)	2	Data Set Ready (DSR)
3	Receive Data (RXD)	4	Request to Send (RTS)
5	Transmit Data (TXD)	6	Clear to Send (CTS)
7	Data Terminal Ready (DTR)	8	Ring Indicator (RI)
9	Ground (GND)	10	NC

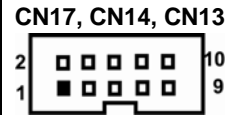

2.4.3 Digital I/O Port (DIO) Connector: CN2

The board is equipped an 8-channel digital I/O connector **CN2** that meets requirements for a system customary automation control. The digital I/O can be configured to control cash drawers, sense warning signals from an Uninterrupted Power System (UPS), or perform store security control. The digital I/O is controlled via software programming.

Pin	Description	Pin	Description
1	DO0	2	DO4
3	DO1	4	DI0
5	DO2	6	DI1
7	DO3	8	DI2
9	GND	10	GND

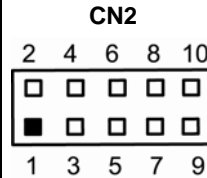

2.4.4 DVI-I & COM1 Connector: CN3

COM1	Description
1	Data Carrier Detect (DCD)
2	Receive Data (RXD)
3	Transmit Data (TXD)
4	Data Terminal Ready (DTR)
5	Ground (GND)
6	Data Set Ready (DSR)
7	Request to Send (RTS)
8	Clear to Send (CTS)
9	Ring Indicator (RI)

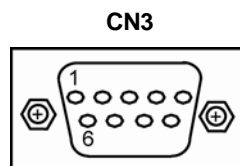

Pin	Description	Pin	Description
1	TX2-	2	TX2+
3	Ground	4	CRT_SPD_CLK
5	CRT_SPD DATA	6	DVI_SPD_CLK
7	DVI_SPD DATA	8	CRT-VSYNC
9	TX1-	10	TX1+
11	Ground	12	NC
13	NC	14	VGAVCC
15	Ground	16	FPDETECT
17	TX0-	18	TX0+
19	Ground	20	NC
21	NC	22	Ground
23	TXC+	24	TXC-
C1	CRT-RED	C2	CRT-GREEN
C3	CRT-BLUE	C4	CRT-HSYNC
C5	VGAGND		

CN3

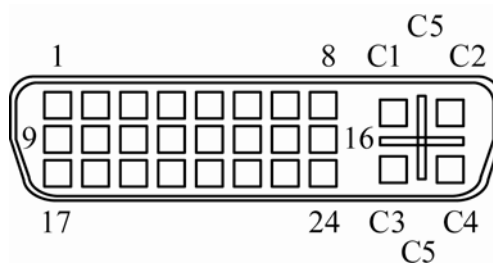

2.4.5 LVDS Backlight Connector: CN27

It is a video connector for working LVDS interface backlight.

Pin	Description
1	+12V
2	+12V
3	+5V
4	ENABLE
5	GND
6	GND
7	GND

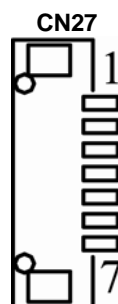

2.4.6 LAN*2 Connector: CN7

The board is equipped with a high performance Plug and Play Ethernet interface fully compliant with the IEEE 802.3 standard. To connect the board to 10-Base-T, 100-Base-T or 1000 Base-T hub, just plug one end of cable to the Ethernet connector and connect the other end (phone jack) to a 10-Base-T, 100-Base-T or 1000 Base-T hub.

COM1	Description
1	LAN2_MDI0+
2	LAN2_MDI0-
3	LAN2_MDI1+
4	LAN2_MDI1-
5	LAN2_MDI2+
6	LAN2_MDI2-
7	LAN2_MDI3+
8	LAN2_MDI3-
A	Active LED
B	100 LAN LED(Green)/ 1000 LAN LED(Orange)

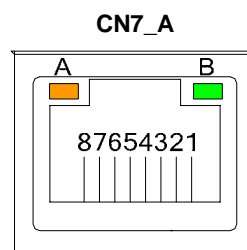

COM1	Description
1	LAN1_MDI0+
2	LAN1_MDI0-
3	LAN1_MDI1+
4	LAN1_MDI1-
5	LAN1_MDI2+
6	LAN1_MDI2-
7	LAN1_MDI3+
8	LAN1_MDI3-
A	Active LED
B	100 LAN LED(Green)/ 1000 LAN LED(Orange)

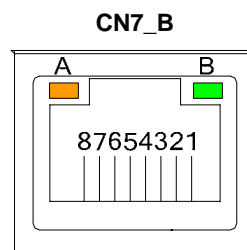

2.4.7 USB*2 + IEEE1394 Connectors: CN11, CN12

The board supports two three-layer USB & IEE1394a connectors, **CN11** and **CN12**.

The upper **CN11** and **CN12** ports are for IEE1394, compliant with the Serial Interface Standard set by the Institute of Electrical and Electronics Engineers, which feature high speed, high bandwidth and hot plug that can connect with IEEE1394 devices and peripherals.

The lower double-deck **CN11** and **CN12** are USB 2.0 ports compliant (480Mbps) that can be connected to any USB peripherals, such as keyboard, mouse, scanner.

Pin	Description
1	+12V
2	GND
3	B0-
4	B0+
5	A0-
6	A0+
7	GND

CN11 , CN12

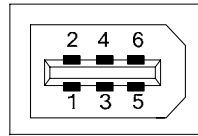

Pin	Description
1, 5	USB Vcc
2, 6	USB -
3, 7	USB +
4, 8	USB GND

CN11 , CN12

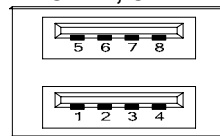

2.4.8 LVDS Flat Panel Connector: CN25

Use this 40-pin Hirose connector to support single/dual channel 18-/24-bit LVDS TFT LCD.

Pin	Description	Pin	Description
1	VCCM	2	VCCM
3	VCCM	4	VCCM
5	VCCM	6	VCCM
7	N.C.	8	N.C.
9	GND	10	GND
11	Channel B D3-	12	Channel B D0-
13	Channel B D3+	14	Channel B D0+
15	GND	16	GND
17	Channel B CLK-	18	Channel B D1-
19	Channel B CLK+	20	Channel B D1+
21	GND	22	GND
23	Channel A D0-	24	Channel B D2-
25	Channel A D0+	26	Channel B D2+
27	GND	28	GND
29	Channel A D1-	30	Channel A D3-
31	Channel A D1+	32	Channel A D3+
33	GND	34	GND
35	Channel A D2-	36	Channel A CLK-
37	Channel A D2+	38	Channel A CLK+
39	GND	40	GND

CN25

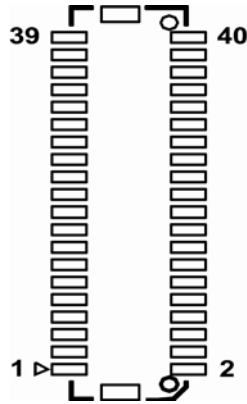

2.4.9 SATA Connectors: CN19, CN20, CN21, CN22

These SATA connectors are for high-speed SATA interface ports and they can be connected to hard disk devices.

Pin	Description
1	GND
2	SATA_TX+
3	SATA_TX-
4	GND
5	SATA_RX-
6	SATA_RX+
7	GND

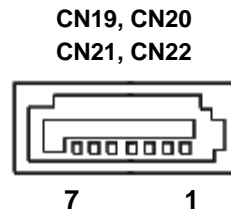

2.4.10 Audio Phone Jack Connector: CN15

After installing onboard audio driver, you may connect speaker to Line Out jack, microphone to MIC in jack.

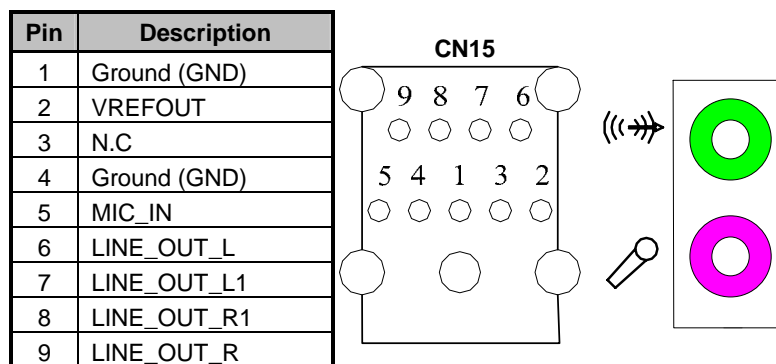

2.4.11 USB Connectors: CN16, CN18

These Universal Serial Bus (USB) connectors on this board are for installing versatile USB interface peripherals. These are 10-pin standard USB connectors.

USB0 and USB1

Pin	Description	Pin	Description
1	+5V	2	+5V
3	USB-	4	USB-
5	USB+	6	USB+
7	Ground (GND)	8	Ground (GND)
9	Ground (GND)	10	Ground (GND)

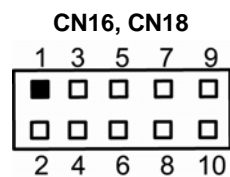

2.4.12 Flat Panel Bezel Connector: CN29

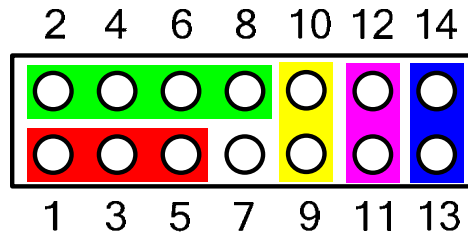

■ Power LED

This 3-pin connector named as Pin 1, 3 and Pin 5 connect the system power LED indicator to such a switch on the case. Pin 1 is assigned as +, and Pin 5 as -. The Power LED lights up when the system is powered ON.

■ External Speaker and Internal Buzzer Connector

Pin 2, 4, 6 and 8 can be connected to the case-mounted speaker unit or internal buzzer. While connecting the CPU card to an internal buzzer, please short pins 2-4; while connecting to an external speaker, you need to set pins 2-4 to Open and connect the speaker cable to pin 8 (+) and pin 2 (-).

■ ATX Power On/Off Button

This 2-pin connector named as Pin 9 and 10 connect the front panel's ATX power button to the CPU card, which allows users to control ATX power supply to be power on/off.

■ System Reset Switch

Pin 11 and 12 can be connected to the case-mounted reset switch that reboots your computer, not turns OFF the power switch. It is a better way to reboot your system for a longer life of the system's power supply.

■ HDD Activity LED

This connection is linked to hard drive activity LED on the control panel. LED flashes when HDD is being accessed. Pin 13 and 14 connect the hard disk drive to the front panel HDD LED, Pin 13 assigned as -, and Pin 14 as +.

2.4.13 Internal Audio Connector: CN23

The board has a 5pin-header connector **CN23** for the internal audio interface. After installing the onboard audio driver, you may connect speaker to Line Out jack, microphone to MIC In.

Pin	Description
1	LINE_OUT_L
2	GND
3	LINE_OUT_R
4	GND
5	MIC_IN

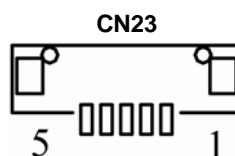

2.4.14 ATX Power Connector: ATX1

Steady and sufficient power can be supplied to all components on the board through the power connector. Please make sure all components and devices are properly installed before connecting the power connector. If you use a 20-pin ATX power supply, please remove the small cover from the power connector before plugging in the power cord; otherwise, please do not remove it.

Pin	Description	Pin	Description
1	3.3V	2	3.3V
3	GND	4	5V
5	GND	6	5V
7	GND	8	PW_OK
9	5V_SB	10	12V
11	3.3V	12	-12V
13	GND	14	PS_ON
15	GND	16	GND
17	GND	18	-5V
19	5V	20	5V

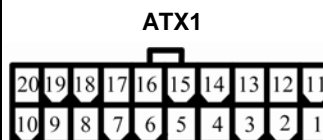

2.4.15 +12V ATX Power Connector: CN1

You can connect it to the ATX12V power supply for CPU core voltage.

Pin	Description
1	GND
2	GND
3	+12V_Vcore
4	+12V_Vcore

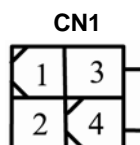

2.4.16 SMBUS Connector: CN4

Connector CN4 is for SMBUS interface support

Pin	Description
1	CLOCK
2	DATA
3	GND

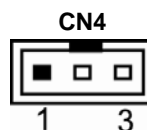

2.4.17 Keyboard and PS/2 Mouse Connector: CN28

The board supports a keyboard and Mouse interface. Connector CN28 is a DIN connector for PS/2 keyboard Connection VIA "Y" Cable.

Pin	Description
1	K/B Data
2	K/B CLK
3	GND
4	VCC
5	M/S Data
6	M/S CLK

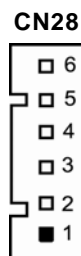

2.4.18 3 Pin Fan Connectors: CN6, CN26

You can connect the system cooling fan cable to **CN6/CN26**. CN6 is for system cooling fan power, and CN26 for GMCH cooling fan power.

Pin	Description
1	Ground
2	+12V
3	Rotation Detection

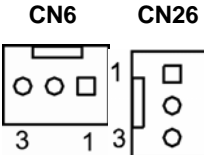

2.4.19 4 Pin Fan Connector: CN5

You can connect the system cooling fan cable to CN5. It is for CPU cooling fan power.

Pin	Description
1	GND
2	+12V
3	Sensor
4	Control

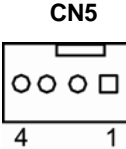

2.4.20 SPDIF Connector: CN24

This SPDIF connector is connecting to the audio module for digital sound output. Connect one end of the SPDIF audio cable to this connector, and the other end to the SPDIF module.

Pin	Description
1	SPDIF-OUT
2	GND

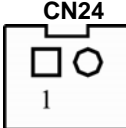

2.4.22 PCI-EXPRESS x 4 Connector: PCIE1

PCIE1 connector is for PCI-Express x 4 graphics interface to support PCI-Express x 4 graphics card.

Pin	Description	Pin	Description
A1	NC	B1	+12V
A2	+12V	B2	+12V
A3	+12V	B3	+12V
A4	GND	B4	GND
A5	NC	B5	SMBCLK
A6	NC	B6	SMBDATA
A7	NC	B7	GND
A8	NC	B8	3.3V
A9	3.3V	B9	NC
A10	3.3V	B10	3.3VSUS
A11	RESET	B11	-PCIE_WAKE
A12	GND	B12	3.3V
A13	SLOT1_CLKP	B13	GND
A14	SLOT1_CLKN	B14	PCIE_OP1
A15	GND	B15	PCIE_ON1
A16	PCIE_IP1	B16	GND
A17	PCIE_IN1	B17	NC
A18	GND	B18	GND
A19	3.3V	B19	SLOT2_CLKP
A20	GND	B20	SLOT2_CLKN
A21	SLOT3_CLKP	B21	GND
A22	SLOT3_CLKN	B22	GND
A23	GND	B23	PCIE_OP2
A24	GND	B24	PCIE_ON2
A25	PCIE_IP2	B25	GND
A26	PCIE_IN2	B26	GND
A27	GND	B27	PCIE_OP3
A28	GND	B28	PCIE_ON3
A29	PCIE_IP3	B29	GND
A30	PCIE_IN3	B30	3.3V
A31	GND	B31	NC
A32	3.3V	B32	NC

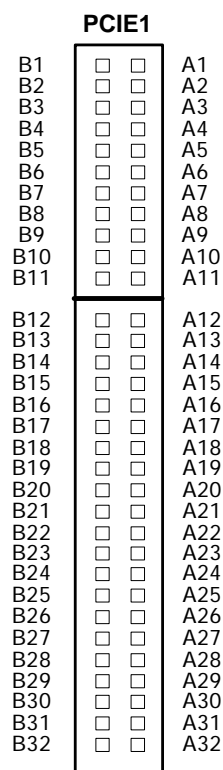

Chapter 3

Hardware Description

3.1 Microprocessors

The **SBC86841** Series supports Intel® Core™ 2 Duo, Pentium® 4, and Pentium® D processors, which make your system operated under Windows 2000/XP and Linux environments. The system performance depends on the microprocessor. Make sure all correct settings are arranged for your installed microprocessor to prevent the CPU from damages.

3.2 BIOS

The **SBC86841** Series uses Award Plug and Play BIOS with a single 4Mbit Flash EPROM.

3.3 System Memory

The **SBC86841** Series industrial CPU card supports two 240-pin unbuffered DDR2 DIMM sockets for a maximum memory of 4GB DDR2 SDRAMs. The memory module can come in sizes of 64MB, 128MB, 256MB, 512MB, 1GB and 2GB.

3.4 I/O Port Address Map

The Intel® Core™ 2 Duo, Pentium® 4, and Pentium® D CPUs can communicate via I/O ports. There are total 1KB port addresses available for assignment to other devices via I/O expansion cards.

Address	Devices
000-01F	DMA controller #1
020-03F	Interrupt controller #1
040-05F	Timer
060-06F	Keyboard controller
070-07F	Real time clock, NMI
080-09F	DMA page register
0A0-0BF	Interrupt controller #2
0C0-0DF	DMA controller #2
0F0	Clear math coprocessor busy signal
0F1	Reset math coprocessor
0F8-0FF	Math processor
1F0-1F8	Fixed disk controller
250-25F	HR I/O
300-31F	Prototype card
380-38F	SDLC #2
3A0-3AF	SDLC #1
3B0-3BF	MDA video card (including LPT1)
3C0-3CF	EGA card
3D0-3DF	CGA card
3F8-3FF	Serial port #1 (COM1)
3E8-3EF	Serial port #3 (COM3)
2F8-2FF	Serial port #2 (COM2)
2E8-2EF	Serial port #4 (COM4)
3F0-3FF	Super I/O

3.5 Interrupt Controller

The **SBC86841 Series** is a 100% PC compatible control board. It consists of 16 interrupt request lines, and four out of them can be programmable. The mapping list of the 16 interrupt request lines is shown as the following table.

IRQ	Parity check error
IRQ0	System timer output
IRQ1	Keyboard
IRQ2	Interrupt rerouting from IRQ8 through IRQ15
IRQ3	Serial port #2
IRQ4	Serial port #1
IRQ5	PCI Device Share
IRQ7	Parallel port #1
IRQ8	Real time clock
IRQ9	ACPI Controller
IRQ10	Serial port #3
IRQ11	Serial port #4
IRQ12	PS/2 Mouse
IRQ13	Math coprocessor
IRQ14	Primary IDE channel
IRQ15	—

MEMO

Chapter 4

Award BIOS Utility

The Phoenix-Award BIOS provides users with a built-in Setup program to modify basic system configuration. All configured parameters are stored in a battery-backed-up RAM (CMOS RAM) to save the Setup information whenever the power is turned off.

4.1 Entering Setup

There are two ways to enter the Setup program. You may either turn ON the computer and press immediately, or press the and/or <Ctrl>, <Alt>, and <Esc> keys simultaneously when the following message appears at the bottom of the screen during POST (Power on Self Test).

TO ENTER SETUP PRESS DEL KEY

If the message disappears before you respond and you still want to enter Setup, please restart the system to try it again. Turning the system power OFF and ON, pressing the "RESET" button on the system case or simultaneously pressing <Ctrl>, <Alt>, and keys can restart the system. If you do not press keys at the right time and the system doesn't boot, an error message will pop out to prompt you the following information:

PRESS <F1> TO CONTINUE, <CTRL-ALT-ESC> OR TO ENTER SETUP

4.2 Control Keys

Up arrow	Move cursor to the previous item
Down arrow	Move cursor to the next item
Left arrow	Move cursor to the item on the left hand
Right arrow	Move to the item in the right hand
Esc key	Main Menu -- Quit and delete changes into CMOS Status Page Setup Menu and Option Page Setup Menu -- Exit current page and return to Main Menu
PgUp/“+” key	Increase the numeric value or make changes
PgDn/“-“ key	Decrease the numeric value or make changes
F1 key	General help, only for Status Page Setup Menu and Option Page Setup Menu
(Shift) F2 key	Change color from total 16 colors. F2 to select color forward, (Shift) F2 to select color backward
F3 key	Reserved
F4 key	Reserved
F5 key	Restore the previous CMOS value from CMOS, only for Option Page Setup Menu
F6 key	Load the default CMOS value from BIOS default table, only for Option Page Setup Menu
F7 key	Load the Setup default, only for Option Page Setup Menu
F8 key	Reserved
F9 key	Reserved
F10 key	Save all the CMOS changes, only for Main Menu

4.3 Getting Help

- **Main Menu**
The online description of the highlighted setup function is displayed at the bottom of the screen.
- **Status Page Setup Menu/Option Page Setup Menu**
Press <F1> to pop out a small Help window that provides the description of using appropriate keys and possible selections for highlighted items. Press <F1> or <Esc> to exit the Help Window.

4.4 The Main Menu

Once you enter the Award BIOS CMOS Setup Utility, the Main Menu appears on the screen. In the Main Menu, there are several Setup functions and a couple of Exit options for your selection. Use arrow keys to select the Setup Page you intend to configure then press <Enter> to accept or enter its sub-menu.

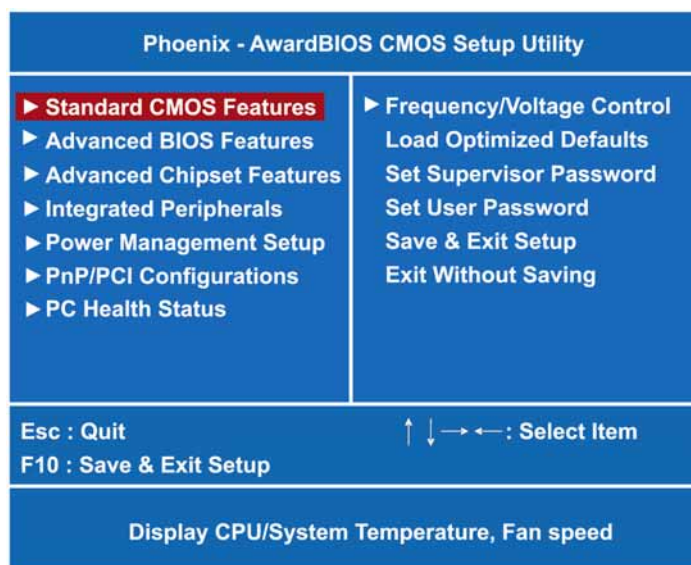

 **NOTE:** If your computer can not boot after making and saving system changes with Setup, the Award BIOS will reset your system to the CMOS default settings via its built-in override feature.

It is strongly recommended that you should avoid changing the chipset's defaults. Both Award and your system manufacturer have carefully set up these defaults that provide the best performance and reliability.

4.5 Standard CMOS Setup Menu

The Standard CMOS Setup Menu displays basic information about your system. Use arrow keys to highlight each item, and use <PgUp> or <PgDn> key to select the value you want in each item.

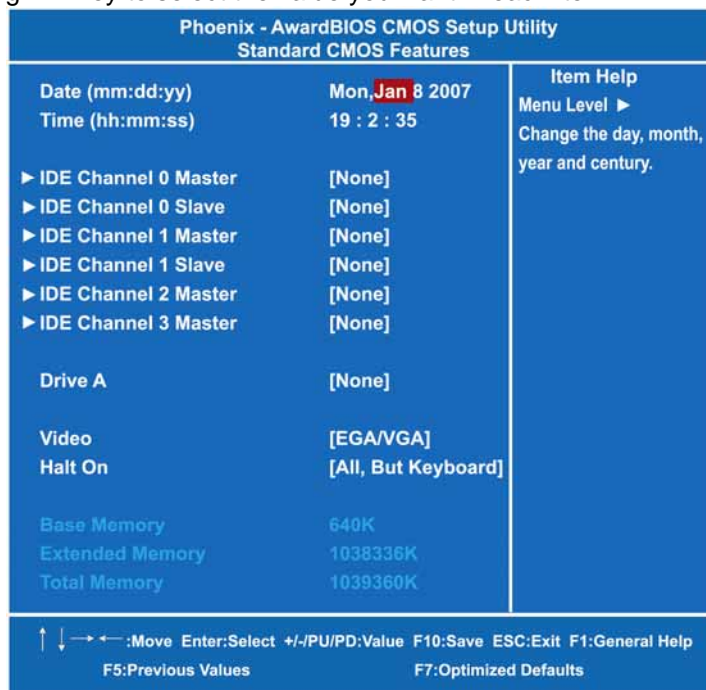

- Date**
 The date format is <day>, <date> <month> <year>. Press <F3> to show the calendar.

day	It is determined by the BIOS and read only, from Sunday to Saturday.
date	It can be keyed with the numerical/ function key, from 1 to 31.
month	It is from January to December.
year	It shows the current year of BIOS.

- Time**
 This item shows current time of your system with the format <hour> <minute> <second>. The time is calculated based on the 24-hour military-time clock. For example, 1 p.m. is 13:00:00.

- **IDE Primary Master/Primary Slave**

These items identify the types of each IDE channel installed in the computer. There are 45 predefined types (Type 1 to Type 45) and 2 user's definable types (Type User) for Enhanced IDE BIOS. Press <PgUp>/<+> or <PgDn>/<-> to select a numbered hard disk type, or directly type the number and press <Enter>. Please be noted your drive's specifications must match the drive table. The hard disk will not work properly if you enter improper information. If your hard disk drive type does not match or is not listed, you can use Type User to manually define your own drive type. If selecting Type User, you will be asked to enter related information in the following items. Directly key in the information and press <Enter>. This information should be provided in the documentation from your hard disk vendor or the system manufacturer.

If the HDD interface controller supports ESDI, select "Type 1".

If the HDD interface controller supports SCSI, select "None".

If the HDD interface controller supports CD-ROM, select "None".

CYLS.	number of cylinders	LANDZONE	landing zone
HEADS	number of heads	SECTORS	number of sectors
PRECOMP	write precom	MODE	HDD access mode

If there is no hard disk drive installed, select NONE and press <Enter>.

- **Video**

Select the display adapter type for your system.

- **Halt On**

This item determines whether the system will halt or not, if an error is detected while powering up.

No errors	The system booting will halt on any errors detected. (default)
All errors	Whenever BIOS detects a non-fatal error, the system will stop and you will be prompted.
All, But Keyboard	The system booting will not stop for a keyboard error; it will stop for other errors.
All, But Diskette	The system booting will not stop for a disk error; it will stop for other errors.
All, But Disk/Key	The system booting will not stop for a keyboard or disk error; it will stop for other errors.

Press <Esc> to return to the Main Menu page.

4.6 Advanced BIOS Features

This section allows you to configure and improve your system, to set up some system features according to your preference.



- **CPU Feature**

Scroll to this item and press <Enter> to view the CPU Feature sub menu.

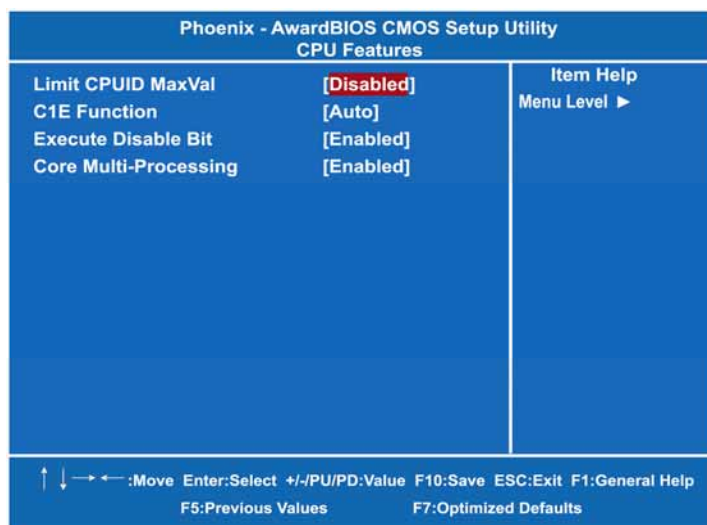

- **Hard Disk Boot Priority**

Scroll to this item and press <Enter> to view the sub menu to decide the disk boot priority.

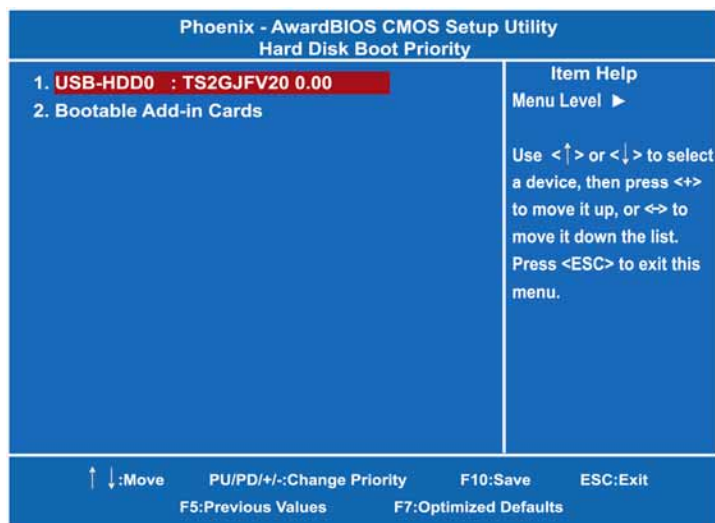

- **Virus Warning**

This option flashes on the screen. During and after the system boot up, any attempt to write to the boot sector or partition table of the hard disk drive will halt the system with the following message. You can run an anti-virus program to locate the problem. The default setting is "Disabled".

! WARNING !
<i>Disk boot sector is to be modified Type "Y" to accept write or "N" to abort write Award Software, Inc.</i>

Enabled	It automatically activates while the system boots up and a warning message appears for an attempt to access the boot sector or hard disk partition table.
Disabled	No warning message will appear for attempts to access the boot sector or hard disk partition table.



NOTE: This function is only available with DOS and other operating systems that do not trap INT13.

- **CPU L1 & L2 Cache**

These two options speed up memory access. However, it depends on the CPU/chipset design. The default setting is "Enabled". CPUs with no built-in internal cache will not provide the "CPU Internal Cache" item on the menu.

Enabled	Enable cache
Disabled	Disable cache

- **Quick Power On Self Test**

This option speeds up Power on Self Test (POST) after you turn on the system power. If set as Enabled, BIOS will shorten or skip some check items during POST. The default setting is "Enabled".

Enabled	Enable Quick POST
Disabled	Normal POST

- **First/Second/Third Boot Device**

These items let you select the 1st, 2nd, and 3rd devices that the system will search for during its boot-up sequence. The wide range of selection includes Floppy, LS120, ZIP100, HDD0~3, SCSI, and CDROM.

- **Boot Other Device**

This item allows the user to enable/disable the boot device not listed on the First/Second/Third boot devices option above. The default setting is "Enabled".

- **Boot Up Floppy Seek**

During POST, BIOS will determine the floppy disk drive type, 40 or 80 tracks. 360Kb type is 40 tracks while 720Kb, 1.2MB and 1.44MB are all 80 tracks. The default value is "Enabled".

Enabled	BIOS searches for floppy disk drive to determine if it is 40 or 80 tracks. Note that BIOS can not tell from 720K, 1.2M or 1.44M drive type as they are all 80 tracks.
Disabled	BIOS will not search for the type of floppy disk drive by track number. There will be no warning message displayed if the drive installed is 360K.

- **Boot Up NumLock Status**

Set the the Num Lock status when the system is powered on. The default value is "On".

- **Gate A20 Option**

The default value is "Fast".

Normal	The A20 signal is controlled by keyboard controller or chipset hardware.
Fast	Default: Fast. The A20 signal is controlled by Port 92 or chipset specific method.

- **Typematic Rate Setting**

This item determines the typematic rate of the keyboard. The default value is "Disabled".

Enabled	Enable typematic rate and typematic delay programming.
Disabled	Disable typematic rate and typematic delay programming. The system BIOS will use default value of these 2 items, controlled by keyboard.

- **Typematic Rate (Chars/Sec)**

This option refers to character numbers typed per second by the keyboard. The default value is "6".

6	6 characters per second
8	8 characters per second
10	10 characters per second
12	12 characters per second
15	15 characters per second
20	20 characters per second
24	24 characters per second
30	30 characters per second

- **Typematic Delay (Msec)**

This option defines how many milliseconds must elapse before a held-down key begins generating repeat characters. The default value is "250".

250	250 msec
500	500 msec
750	750 msec
1000	1000 msec

- **Security Option**

This item allows you to limit access to the system and Setup, or just to Setup. The default value is "Setup".

System	If a wrong password is entered at the prompt, the system will not boot, the access to Setup will be denied, either.
Setup	If a wrong password is entered at the prompt, the system will boot, but the access to Setup will be denied.



NOTE: To disable the security, select **PASSWORD SETTING** at Main Menu and then you will be asked to enter a password. Do not type anything, just press <Enter> and it will disable the security. Once the security is disabled, the system will boot and you can enter Setup freely.

- **APIC Mode**
Use this item to enable or disable APIC (Advanced Programmable Interrupt Controller) mode that provides symmetric multi-processing (SMP) for systems.
- **MPS Version Control For OS**
This item specifies the version of the Multiprocessor Specification (MPS). Version 1.4 has extended configuration tables to improve support for multiple PCI bus configurations and provide future expandability.
- **Small Logo (EPA) Show**
If enabled, the EPA logo will appear during system booting up; if disabled, the EPA logo will not appear.

Press <Esc> to return to the Main Menu page.

4.7 Advanced Chipset Features

This section contains completely optimized chipset's features on the board that you are strongly recommended to leave all items on this page at their default values unless you are very familiar with the technical specifications of your system hardware.

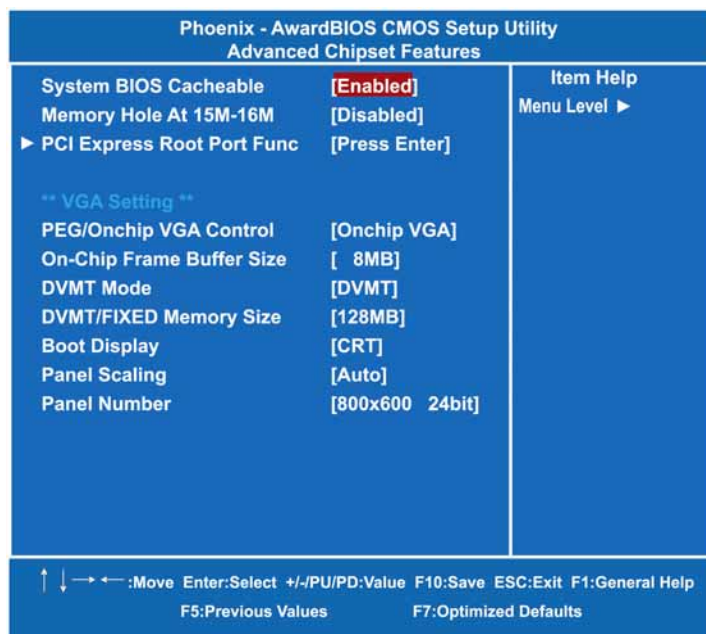

- System BIOS Cacheable**
 Selecting Enabled allows caching of the system BIOS ROM at F0000h-FFFFFh, resulting in better system performance. However, if any program writes to this memory area, a system error may result. The default value is "Disabled".
- Memory Hole At 15M-16M**
 You can reserve this area of system memory for ISA adapter ROM. When this area is reserved, it cannot be cached. The user information of peripherals that need to use this area of system memory usually discusses their memory requirements.

- **PCI Express Root Port Func**

Scroll to this item and press <Enter> to view the sub menu to decide the PCI Express Port.

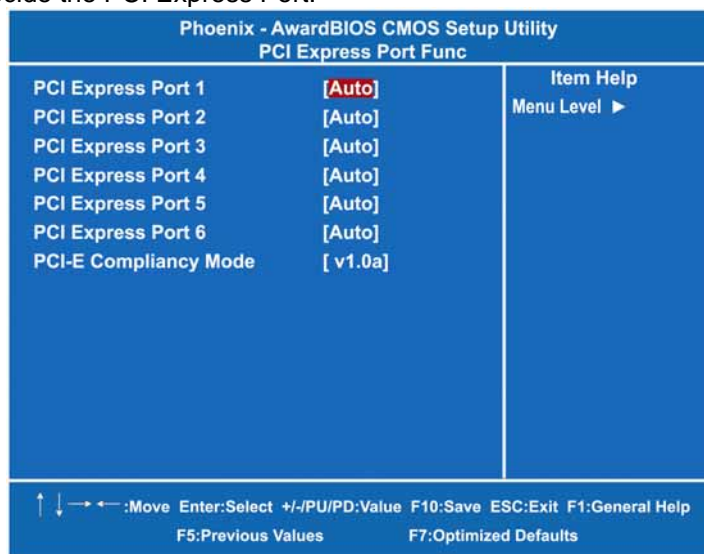

Press <Esc> to return to the Advanced Chipset Features page.

*** **VGA Setting** ***

- **PEG/Onchip VGA Control**

Use this item to choose the primary display card.

- **On-Chip Frame Buffer Size**

Use this item to set the VGA frame buffer size.

- **DVMT Mode**

DVMT (Dynamic Video Memory Technology) helps you select the video mode.

- **DVMT/Fixed Memory Size**

DVMT (Dynamic Video Memory Technology) allows you to select a maximum size of dynamic amount usage of the video memory. The system would configure the video memory dependent on your application.

- **Boot Display**
This item is for Intel define ADD card only.

Press <Esc> to return to the Main Menu page.

4.8 Integrated Peripherals

This section allows you to configure your SuperIO Device, IDE Function and Onboard Device.

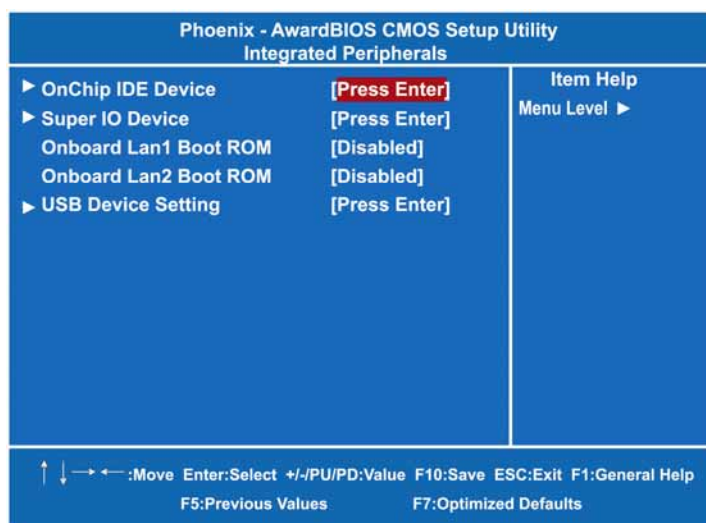

- **OnChip IDE Device**

Scroll to this item and press <Enter> to view the sub menu OnChip IDE Device.

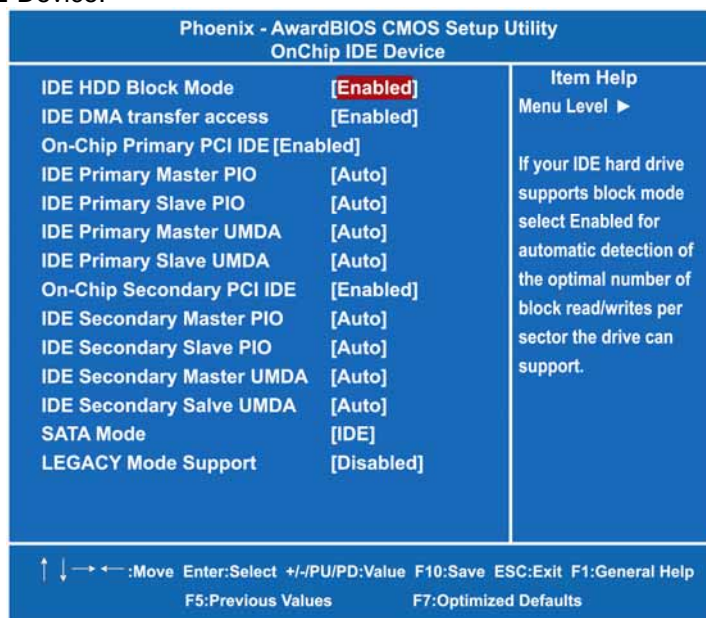

- **IDE HDD Block Mode**

Block mode is also called block transfer, multiple commands, or multiple sector read/write. If your IDE hard drive supports block mode (most new drives do), select Enabled for automatic detection of the optimal number of block read/writes per sector the drive can support.

- **IDE DMA transfer access**

Automatic data transfer between system memory and IDE device with minimum CPU intervention. This improves data throughput and frees CPU to perform other tasks.

- **On-Chip Primary/Secondary PCI IDE**

The integrated peripheral controller contains an IDE interface with support for two IDE channels. Select Enabled to activate each channel separately. The default value is "Enabled".



NOTE: Choosing Disabled for these options will automatically remove the IDE Primary Master/Slave PIO and/or IDE Secondary

Master/Slave PIO items on the menu.

- **IDE Master/Slave PIO**
The four IDE PIO (Programmed Input/Output) fields let you set a PIO mode (0-4) for each of the four IDE devices that the onboard IDE interface supports. Modes 0 to 4 provide successively increased performance. In Auto mode, the system automatically determines the best mode for each device.
- **IDE Master/Slave UDMA**
Select the mode of operation for the IDE drive. Ultra DMA-33/66/100/133 implementation is possible only if your IDE hard drive supports it and the operating environment includes a DMA driver. If your hard drive and your system software both support Ultra DMA-33/66/100/133, select Auto to enable UDMA mode by BIOS.
- **SATA Mode**
There are these options for you to set up SATA mode: IDE, RAID or AHCI.
 **NOTE:** *ICH8DO supports AHCI under Microsoft Windows VISTA and Microsoft Windows XP. ICH8 only supports AHCI under Microsoft Windows VISTA.*
- **LEGACY Mode Support**
Legacy mode support allows devices to function in an operating environment that is not USB-aware.

Press <Esc> to return to the Integrated Peripherals page.

- **Super IO Device**

Scroll to this item and press <Enter> to view the sub menu Super IO Device.



- **Onboard FDC Controller**
Select Enabled if your system has a floppy disk controller (FDC) installed on the system board and you wish to use it. If you install and-in FDC or the system has no floppy drive, select Disabled in this field. The options available are Enabled, Disabled.
- **Onboard Serial Port 1/2/3/4**
Select an address and corresponding interrupt for the serial port. Options: 3F8/IRQ4, 2E8/IRQ3, 3E8/IRQ4, 2F8/IRQ3, Disabled, Auto.
- **Serial Port 1/2/3/4 Use IRQ**
These items assign which I/O address to access onboard serial port 1/2/3/4.
- **Onboard Parallelel Port**
This item allows you to determine access onboard parallel port controller with which I/O address. The options available are 378H/IRQ7, 278H/IRQ5, 3BC/IRQ7, Disabled. *The 3BC option does not support any EPP modes.*

- **Parallel Port Mode**
Select an operating mode for the onboard parallel (printer) port. Select Normal unless your hardware and software require one of the other modes offered in this field. The options available are EPP1.9, ECP, SPP, ECPEPP1.7, EPP1.7.
- **ECP Mode Use DMA**
Select a DMA channel for the parallel port for use during ECP mode.
- **PWRON After PWR-Fail**
This item enables your computer to automatically restart or return to its operating status.

Press <Esc> to return to the Integrated Peripherals page.

- **Onboard Lan1/Lan2 Boot ROM**

Use this item to enable or disable the Boot ROM function of the onboard LAN1/LAN2 chips when the system boots up.

- **USB Device Setting**

Scroll to this item and press <Enter> to view the sub menu USB Device Setting. USB (CN16) is not working when USB2.0 Controller is disabled.

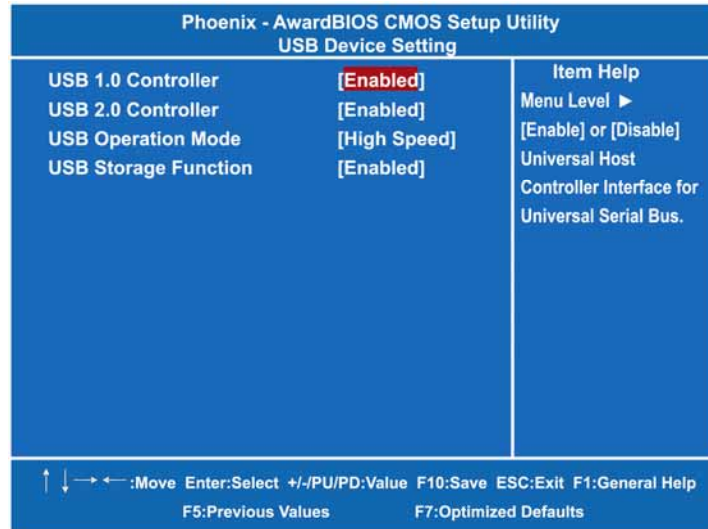

Press <Esc> to return to the Integrated Peripherals page, and press it again, return to the Main Menu page.

4.9 Power Management Setup

The Power Management Setup allows you to save energy of your system effectively. It will shut down the hard disk and turn OFF video display after a period of inactivity.

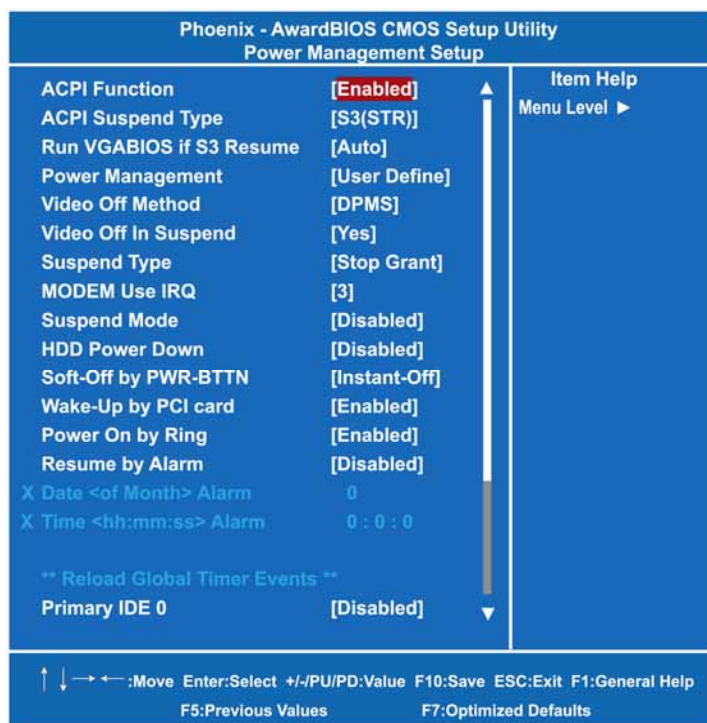

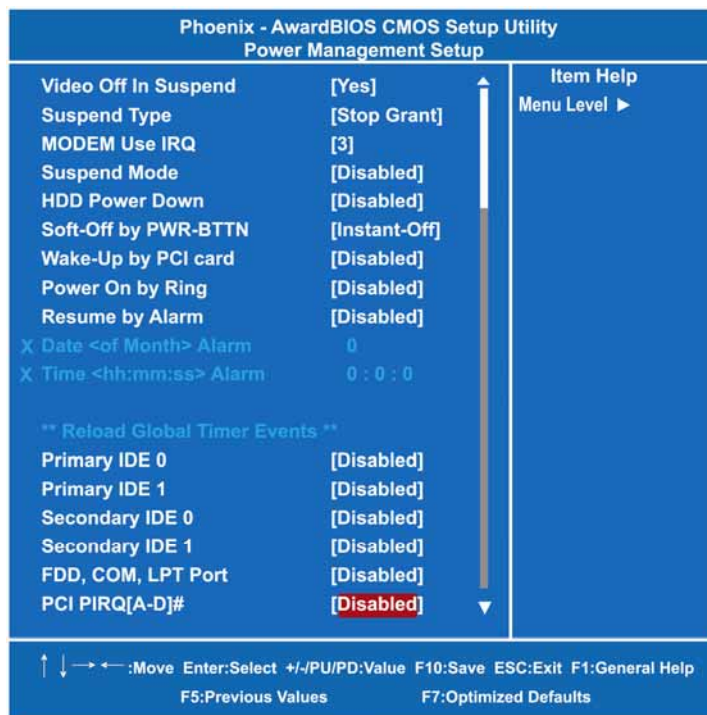

- ACPI Function**
 This item allows you to enable/disable the Advanced Configuration and Power Management (ACPI). The function is always "Enabled".
- ACPI Suspend Type**
 This item specifies the power saving modes for ACPI function. If your operating system supports ACPI, such as Windows 98SE, Windows ME and Windows 2000, you can choose to enter the Standby mode in S1 (POS) or S3 (STR) fashion through the setting of this field. Options are:
 - [S1(POS)] The S1 sleep mode is a low power state. In this state, no system context is lost (CPU or chipset) and hardware maintains all system context.
 - [S3(STR)] The S3 sleep mode is a lower power state where the information of system configuration and open applications/files is saved to main memory that remains powered while most other hardware components turn off to save energy. The information stored in memory will be used to restore the system when a "wake up" event occurs.

- **Run VGABIOS if S3 Resume**

When this item is set Auto, the system will run VGA BIOS if it is resumed from the S3 state.

- **Power Management**

This option allows you to select the type (or degree) of power saving for Doze, Standby, and Suspend modes. The table below describes each power management mode:

Max Saving	It is maximum power savings, only available for SL CPUs. The inactivity period is 1 minute in each mode.
User Define	It sets each mode. Select time-out periods in the PM Timers section.
Min Saving	It is minimum power savings. The inactivity period is 1 hour in each mode (except the hard drive).
Disabled	Default value

- **Video Off Method**

This setting determines the manner in which the monitor is blanked.

V/H SYNC+Blank	Turns OFF vertical and horizontal synchronization ports and writes blanks to the video buffer
DPMS	Select this option if your monitor supports the Display Power Management Signaling (DPMS) standard of the Video Electronics Standards Association (VESA). Use the software supplied for your video subsystem to select video power management values.
Blank Screen	System only writes blanks to the video buffer.

- **Video Off In Suspend**

This item defines if the video is powered down when the system is put into suspend mode.

- **Suspend Type**

If this item is set to the default Stop Grant, the CPU will go into Idle Mode during power saving mode.

- **Modem Use IRQ**

If you want an incoming call on a modem to automatically resume the system from a powersaving mode, use this item to specify the interrupt request line (IRQ) used by the modem. You might have to connect the fax/modem to the board Wake On Modem connector

for working this feature.

- **Suspend Mode**

After the selected period of system inactivity (1 minute to 1 hour), all devices except the CPU shut off. The default value is "Disabled".

Disabled	System will never enter SUSPEND mode
1/2/4/6/8/10/20/30/40 Min/1 Hr	Defines the continuous idle time before the system entering SUSPEND mode. If any item defined in (J) is enabled & active, SUSPEND timer will be reloaded

- **HDD Power Down**

If HDD activity is not detected for the length of time specified in this field, the hard disk drive will be powered down while all other devices remain active.

- **Soft-Off by PWR-BTTN**

This option only works with systems using an ATX power supply. It also allows the user to define which type of soft power OFF sequence the system will follow. The default value is "Instant-Off".

Instant-Off	This option follows the conventional manner systems perform when power is turned OFF. Instant-Off is a soft power OFF sequence requiring only the switching of the power supply button to OFF
Delay 4 Sec.	Upon turning OFF system from the power switch, this option will delay the complete system power OFF sequence by approximately 4 seconds. Within this delay period, system will temporarily enter into Suspend Mode enabling you to restart the system at once.

- **Wake-Up by PCI card**

If enable this item, the system can automatically resume when the PCI Modem or PCI LAN card receives an incoming call.

- **Power On by Ring**

This option allows the system to resume or wake up upon detecting any ring signals coming from an installed modem. The default value is "Enabled".

- **Resume by Alarm**

If enable this item, the system can automatically resume after a fixed time in accordance with the system's RTC (realtime clock).

**** Reload Global Timer Events ****

Global Timer (power management) events can prevent the system from entering a power saving mode or can awaken the system from such a mode.

- **Primary/Secondary IDE 0/1**
Use this item to configure the IDE devices monitored by the system.
- **FDD, COM, LPT Port**
Use this item to configure the FDD, COM and LPT ports monitored by the system.
- **PCI PIRQ[A-D]#**
This item can be used to detect PCI device activities; if no activity, the system will enter the sleep mode.

Press <Esc> to return to the Main Menu page.

4.10 PnP/PCI Configuration Setup

This section describes the configuration of PCI (Personal Computer Interconnect) bus system, which allows I/O devices to operate at speeds close to the CPU speed while communicating with other important components. This section covers very technical items that only experienced users could change default settings.

Phoenix - AwardBIOS CMOS Setup Utility PnP/PCI Configurations		
Reset Configuration Data	[Disabled]	Item Help Menu Level ▶
Resources Controlled By X IRQ Resources	[Auto(ESCD)] Press Enter	Default is Disabled. Select Enabled to reset Extended System Configuration Data (ESCD) when you exit Setup if you have installed a new add-on and the system reconfiguration has caused such a serious conflict that the OS cannot boot.
PCI/VGA Palette Snoop	[Disabled]	
** PCI Express relative items **		
Maximum Payload Size	[128]	
↑ ↓ → ← :Move Enter:Select +/-/PU/PD:Value F10:Save ESC:Exit F1:General Help F5:Previous Values F7:Optimized Defaults		

- Reset Configuration Data**
 Normally, you leave this item Disabled. Select Enabled to reset Extended System Configuration Data (ESCD) when you exit Setup or if installing a new add-on cause the system reconfiguration a serious conflict that the operating system can not boot. Options: Enabled, Disabled.
- Resources Controlled By**
 The Award Plug and Play BIOS can automatically configure all boot and Plug and Play-compatible devices. If you select Auto, all interrupt request (IRQ), DMA assignment, and Used DMA fields disappear, as the BIOS automatically assigns them. The default value is "Manual".
- IRQ Resources**
 When resources are controlled manually, assign each system interrupt to one of the following types in accordance with the type

of devices using the interrupt:

1. Legacy ISA Devices compliant with the original PC AT bus specification, requiring a specific interrupt (such as IRQ4 for serial port 1).
2. PCI/ISA PnP Devices compliant with the Plug and Play standard, whether designed for PCI or ISA bus architecture.

The default value is *"PCI/ISA PnP"*.

- **PCI/VGA Palette Snoop**

Some non-standard VGA display cards may not show colors properly. This item allows you to set whether MPEG ISA/VESA VGA Cards can work with PCI/VGA or not. When enabled, a PCI/VGA can work with a MPEG ISA/VESA VGA card; when disabled, a PCI/VGA cannot work with a MPEG ISA/VESA Card.

**** PCI Express relative items ****

- **Maximum Payload Size**

When using DDR SDRAM and Buffer size selection, another consideration in designing a payload memory is the size of the buffer for data storage. Maximum Payload Size defines the maximum TLP (Transaction Layer Packet) data payload size for the device.

Press <Esc> to return to the Main Menu page.

4.11 PC Health Status

This section supports hardware monitoring that lets you monitor those parameters for critical voltages, temperatures and fan speed of the board.

Phoenix - AwardBIOS CMOS Setup Utility		Item Help
PC Health Status		Menu Level ▶
Shutdown Temperature	Disabled	
Current System Temp	33°C/91°F	
Current CPU Temperature	84°C/183°F	
GMCH Speed	0 RPM	
CPU Speed	2518 RPM	
Vcore	1.26 V	
VDIMM	1.02 V	
+ 3.3 (V)	3.26 V	
+ 12.0 (V)	11.90 V	
VCC (V)	2.94 V	
5VSB(V)	5.13 V	

↑ ↓ ← → :Move Enter:Select +/-/PU/PD:Value F10:Save ESC:Exit F1:General Help
F5:Previous Values F7:Optimized Defaults

- **Shutdown Temperature**
It helps you set the maximum temperature they system can reach before powering down.
- **Current SYSTEM Temperature**
Show you the current system temperature.
- **Current CPU Temperature**
These read-only fields show the functions of the hardware thermal sensor by CPU thermal diode that monitors the chip blocks to ensure a stable system.
- **Vcore +3.3V/+5V/+12V/VBAT(V)/5VSB**
Show you the voltage of +3.3V/+5V/+12V.

Press <Esc> to return to the Main Menu page.

4.12 Frequency/Voltage Control

This section is to control the CPU frequency and Supply Voltage, DIMM OverVoltage and AGP voltage.

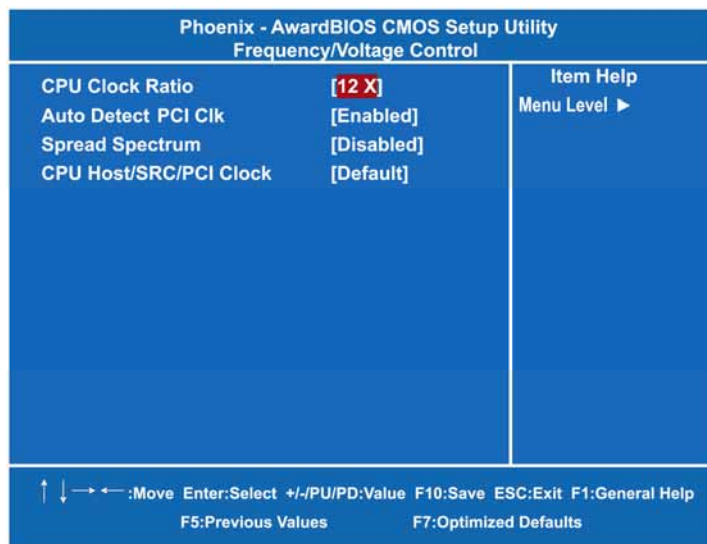

- **CPU Clock Ratio**
Use this item to select the CPU's frequency.
- **Auto Detect PCI Clk**
The enabled item can automatically disable the clock source for a PCI slot without a module, to reduce EMI (ElectroMagnetic Interference).
- **Spread Spectrum**
If spread spectrum is enabled, EMI (ElectroMagnetic Interference) generated by the system can be significantly reduced.

Press <Esc> to return to the Main Menu page.

4.13 Load Optimized Defaults

This option allows you to load your system configuration with default values. These default settings are optimized to enable high performance features.

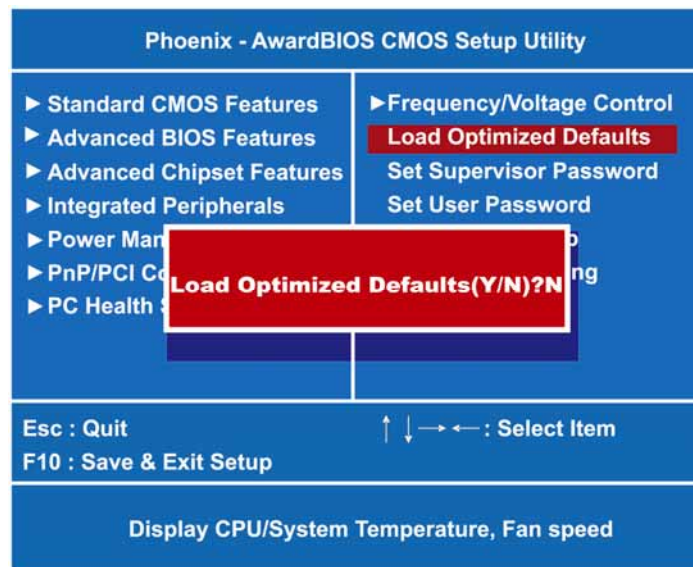

To load CMOS SRAM with SETUP default values, please enter "Y". If not, please enter "N".

4.14 Set Supervisor/User Password

You can set a supervisor or user password, or both of them. The differences between them are:

1. **Supervisor password:** You can enter and change the options on the setup menu.
2. **User password:** You can just enter, but have no right to change the options on the setup menu.

When you select this function, the following message will appear at the center of the screen to assist you in creating a password.

ENTER PASSWORD

Type a maximum eight-character password, and press <Enter>. This typed password will clear previously entered password from the CMOS memory. You will be asked to confirm this password. Type this password again and press <Enter>. You may also press <Esc> to abort this selection and not enter a password.

To disable the password, just press <Enter> when you are prompted to enter a password. A message will confirm the password is getting disabled. Once the password is disabled, the system will boot and you can enter Setup freely.

PASSWORD DISABLED

When a password is enabled, you have to type it every time you enter the Setup. It prevents any unauthorized persons from changing your system configuration.

Additionally, when a password is enabled, you can also require the BIOS to request a password every time the system reboots. This would prevent unauthorized use of your computer.

You decide when the password is required for the BIOS Features Setup Menu and its Security option. If the Security option is set to "System", the password is required during booting up and entry into the Setup; if it is set as "Setup", a prompt will only appear before entering the Setup.

4.15 Save & Exit Setup

This section allows you to determine whether or not to accept your modifications. Type "Y" to quit the setup utility and save all changes into the CMOS memory. Type "N" to bring you back to the Setup utility.

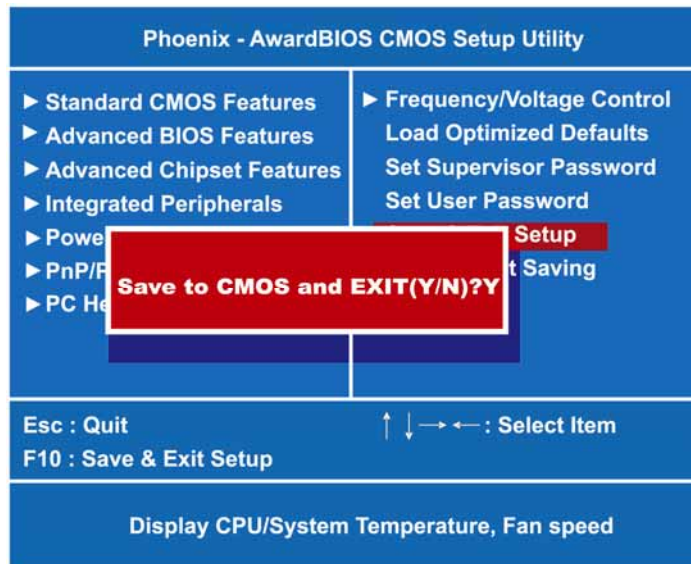

4.16 Exit Without Saving

Select this option to exit the Setup utility without saving changes you have made in this session. Type "Y", and it will quit the Setup utility without saving your modifications. Type "N" to return to the Setup utility.

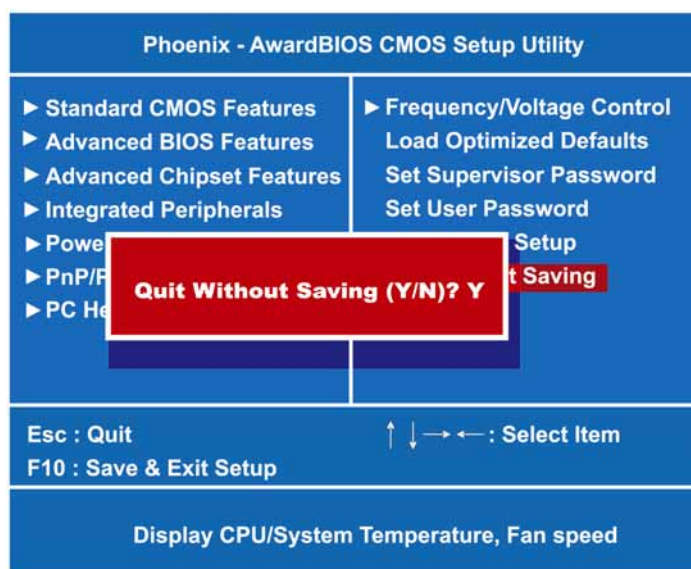

MEMO

Appendix A

Watchdog Timer

Watchdog Timer Setting

After the system stops working for a while, it can be auto-reset by the Watchdog Timer. The integrated Watchdog Timer can be set up in the system reset mode by program.

Using the Watchdog Function

Start

↓

Un-Lock WDT:

O 2E 87 ; Un-lock super I/O
O 2E 87 ; Un-lock super I/O

↓

Select Logic device:

O 2E 07
O 2F 08

↓

Activate WDT:

O 2E 30
O 2F 01

↓

Set Second or Minute :

O 2E F5
O 2F N N=00 or 08

↓

Set base timer :

O 2E F6
O 2F M=00,01,02,...FF(Hex) ,Value=0 to 255

↓

WDT counting re-set timer :

O 2E F6
O 2F M ; M=00,01,02,...FF

; IF to disable WDT:

O 2E 30

O 2F 00 ; Can be disable at any time

- Timeout Value Range
 - 1 to 255
 - Minute / Second
- Program Sample

2E, 87	
2E, 87	
2E, 07	
2F, 08	Logical Device 8
2E, 30	Activate
2F, 01	
2E, F5	
2F, N	Set Minute or Second N=08 (Min),00(Sec)
2E, F6	
2F, M	Set Value M = 00 ~ FF

Appendix B

Digital I/O

Digital I/O Software Programming

- GPI program sample:

O 2E 87	
O 2E 87	
O 2E 07	
O 2F 08	Select Device 8
O 2E 30	
O 2F F2	Activate GPIO5
O 2E E0	
O 2F FF	GPIO5 pins are programmed as input pins.
O 2E E1	Read only from pin
I 2F	Display input read value

- GPO program sample:

O 2E 87	
O 2E 87	
O 2E 07	
O 2F 08	Select Device 8
O 2E 30	
O 2F F2	Activate GPIO5
O 2E E0	
O 2F 00	GPIO5 pins are programmed as output pins.
O 2E E1	
O 2F FF	GPIO5 port output HI